

(19) World Intellectual Property
Organization
International Bureau



(43) International Publication Date
9 September 2005 (09.09.2005)

PCT

(10) International Publication Number
WO 2005/083408 A1

- (51) International Patent Classification⁷: G01N 27/02, 33/34
- (21) International Application Number: PCT/SE2005/000276
- (22) International Filing Date: 25 February 2005 (25.02.2005)
- (25) Filing Language: Swedish
- (26) Publication Language: English
- (30) Priority Data:
60/521,145 27 February 2004 (27.02.2004) US
0400491-7 27 February 2004 (27.02.2004) SE
- (71) Applicant (for all designated States except US): DAPROX AB [SE/SE]; P.O. Box 120, S-127 23 Skärholmen (SE).
- (72) Inventor; and
- (75) Inventor/Applicant (for US only): ÅKERBLOM, Bengt [SE/SE]; Vårby Allé 23, S-143 40 Vårby (SE).
- (74) Agent: ALBIHNS STOCKHOLM AB; P.O. Box 5581, S-114 85 Stockholm (SE).
- (81) Designated States (unless otherwise indicated, for every kind of national protection available): AE, AG, AL, AM, AT, AU, AZ, BA, BB, BG, BR, BW, BY, BZ, CA, CH, CN, CO, CR, CU, CZ, DE, DK, DM, DZ, EC, EE, EG, ES, FI, GB, GD, GE, GH, GM, HR, HU, ID, IL, IN, IS, JP, KE, KG, KP, KR, KZ, LC, LK, LR, LS, LT, LU, LV, MA, MD, MG, MK, MN, MW, MX, MZ, NA, NI, NO, NZ, OM, PG, PH, PL, PT, RO, RU, SC, SD, SE, SG, SK, SL, SM, SY, TJ, TM, TN, TR, TT, TZ, UA, UG, US, UZ, VC, VN, YU, ZA, ZM, ZW.
- (84) Designated States (unless otherwise indicated, for every kind of regional protection available): ARIPO (BW, GH, GM, KE, LS, MW, MZ, NA, SD, SL, SZ, TZ, UG, ZM, ZW), Eurasian (AM, AZ, BY, KG, KZ, MD, RU, TJ, TM), European (AT, BE, BG, CH, CY, CZ, DE, DK, EE, ES, FI, FR, GB, GR, HU, IE, IS, IT, LT, LU, MC, NL, PL, PT, RO, SE, SI, SK, TR), OAPI (BF, BJ, CF, CG, CI, CM, GA, GN, GQ, GW, ML, MR, NE, SN, TD, TG).
- Published:
— with international search report
- For two-letter codes and other abbreviations, refer to the "Guidance Notes on Codes and Abbreviations" appearing at the beginning of each regular issue of the PCT Gazette.

(54) Title: PROCESS AND GAUGE FOR MEASURING FIBER CONCENTRATION

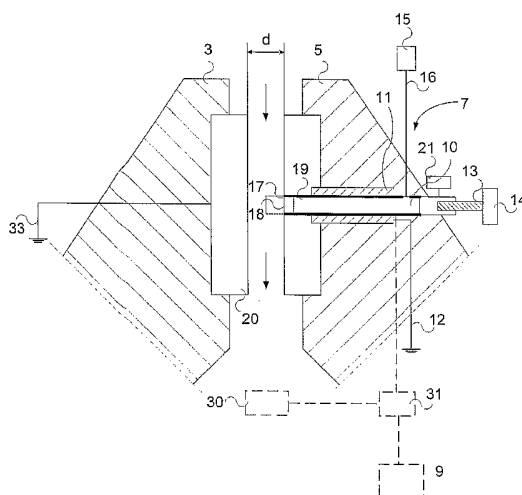

(57) Abstract: The present invention relates to a method for measuring the degree of fibre concentration in a pulp in a machine (1), in particular a refiner for the manufacture of paper pulp, which machine (1) comprises a stator (5) and an opposing rotor (3), which form a grinding gap (6) for the pulp. The stator (5) is provided with at least one sensor device (7), designed to interact with a rotor surface and comprising an impedance meter body (10) with a sensor surface (18) which impedance meter body (10) is mounted in the stator (5) in such a way that it can move axially. The method is characterized in that measurements of the impedance between the rotor surface and the sensor surface (18) are carried out during an axial movement of the impedance meter body (10) and in that the measured impedance differences are utilized together with the size of the movement to determine the dielectric constant of the pulp, from which the degree of fibre concentration in the pulp is derived. The invention also relates to a sensor device (7) arranged to carry out the method according to the above.

WO 2005/083408 A1