

(19) World Intellectual Property
Organization
International Bureau



(43) International Publication Date
7 October 2004 (07.10.2004)

PCT

(10) International Publication Number
WO 2004/085070 A1

(51) International Patent Classification⁷: **B02C 7/14**,
G01B 7/14, D21D 1/30

(21) International Application Number:
PCT/SE2004/000339

(22) International Filing Date: 9 March 2004 (09.03.2004)

(25) Filing Language: Swedish

(26) Publication Language: English

(30) Priority Data:
0300794-5 24 March 2003 (24.03.2003) SE

(71) Applicant (for all designated States except US): **DAPROX AB** [SE/SE]; P.O. Box 120, S-127 23 Skärholmen (SE).

(72) Inventor; and

(75) Inventor/Applicant (for US only): **ÅKERBLOM, Bengt** [SE/SE]; Vårby Allé 23, S-143 40 Vårby (SE).

(74) Agent: **ALBIHNS STOCKHOLM AB**; P.O. Box 5581, S-114 85 Stockholm (SE).

(81) Designated States (unless otherwise indicated, for every kind of national protection available): AE, AG, AL, AM, AT, AU, AZ, BA, BB, BG, BR, BW, BY, BZ, CA, CH, CN, CO, CR, CU, CZ, DE, DK, DM, DZ, EC, EE, EG, ES, FI, GB, GD, GE, GH, GM, HR, HU, ID, IL, IN, IS, JP, KE, KG, KP, KR, KZ, LC, LK, LR, LS, LT, LU, LV, MA, MD, MG, MK, MN, MW, MX, MZ, NA, NI, NO, NZ, OM, PG, PH, PL, PT, RO, RU, SC, SD, SE, SG, SK, SL, SY, TJ, TM, TN, TR, TT, TZ, UA, UG, US, UZ, VC, VN, YU, ZA, ZM, ZW.

(84) Designated States (unless otherwise indicated, for every kind of regional protection available): ARIPO (BW, GH, GM, KE, LS, MW, MZ, SD, SL, SZ, TZ, UG, ZM, ZW), Eurasian (AM, AZ, BY, KG, KZ, MD, RU, TJ, TM), European (AT, BE, BG, CH, CY, CZ, DE, DK, EE, ES, FI, FR, GB, GR, HU, IE, IT, LU, MC, NL, PL, PT, RO, SE, SI, SK, TR), OAPI (BF, BJ, CF, CG, CI, CM, GA, GN, GQ, GW, ML, MR, NE, SN, TD, TG).

Published:
— with international search report

For two-letter codes and other abbreviations, refer to the "Guidance Notes on Codes and Abbreviations" appearing at the beginning of each regular issue of the PCT Gazette.

(54) Title: A METHOD AND A SENSOR DEVICE FOR MEASURING THE DISTANCE BETWEEN A STATOR AND AN OPPOSING ROTOR

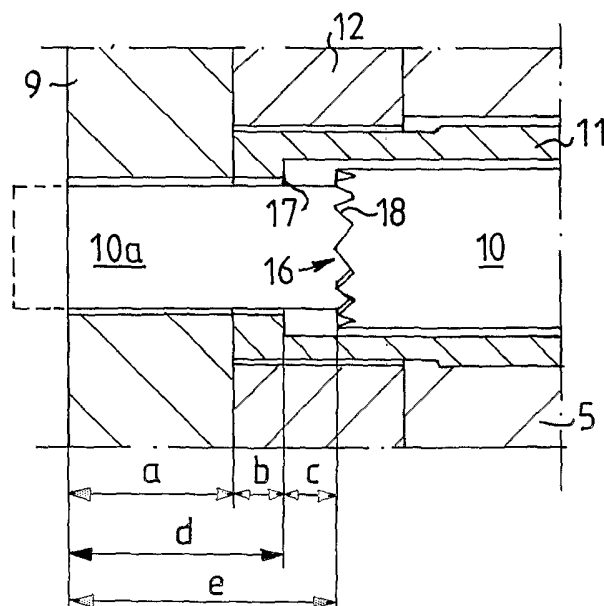

(57) Abstract: A sensor device for measuring distance between a stator and a rotor in a machine is of the magnetic type and is intended to be mounted in the stator in order to interact with an opposing surface on the rotor. A sensor body (10) can be moved axially in a housing (11) mounted in the stator by means of an operating mechanism (13) and has a stop (16) at a predetermined distance (e) from its end surface designed to interact with a corresponding stop (17) inside the housing. This distance (e) exceeds the distance (d) between the stop (17) in the housing and the end of the sensor body (10) by a predetermined distance (c) when the sensor body is in its normal measuring position. These stops (16, 17) make possible a particularly accurate calibration of the sensor device.

WO 2004/085070 A1