



US 20160258893A1

(19) **United States**

(12) **Patent Application Publication**
Åkerblom

(10) **Pub. No.: US 2016/0258893 A1**
(43) **Pub. Date: Sep. 8, 2016**

(54) **A DEVICE FOR DETECTING PROFILE IN REFINER AND METHOD THEREFORE**

(52) **U.S. Cl.**
CPC *G01N 27/045* (2013.01); *G01N 33/34* (2013.01); *G01N 33/40* (2013.01)

(71) Applicant: **DAPROX AB**, Kungens Kurva (SE)

(72) Inventor: **Bengt Åkerblom**, Vårby (SE)

(57) **ABSTRACT**

(21) Appl. No.: **15/034,140**

(22) PCT Filed: **Oct. 13, 2014**

(86) PCT No.: **PCT/SE2014/051209**

§ 371 (c)(1),

(2) Date: **May 3, 2016**

(30) **Foreign Application Priority Data**

Nov. 4, 2013 (SE) 1351299-1

Publication Classification

(51) **Int. Cl.**
G01N 27/04 (2006.01)
G01N 33/40 (2006.01)
G01N 33/34 (2006.01)

The invention regards a measuring device, comprising a conductor body (7), for detecting the degree of fiber concentration and/or steam point (SP) of a fiber pad (33) being pulped, during use of the device (3), in a grinding gap (15) between refiner discs (11, 13) of a refiner (1). The conductor body (7) exhibits a first electric contact surface (17) adapted to provide electrical contact with a second electric contact surface (19) for transferring an electric current via the fiber pad (33) material. The invention also regards a method for detecting the degree of fiber concentration and/or steam point (SP) of a fiber pad (33). The method comprises the steps of mounting of the conductor body (7) to one of the refiner discs (13), grinding the fiber pad (33) material between the refiner discs (11, 13), detecting alteration of the conductivity and/or electrical resistivity of the fiber pad (33) material, and adjusting inflow of water and/or fiber material from said detected alteration.

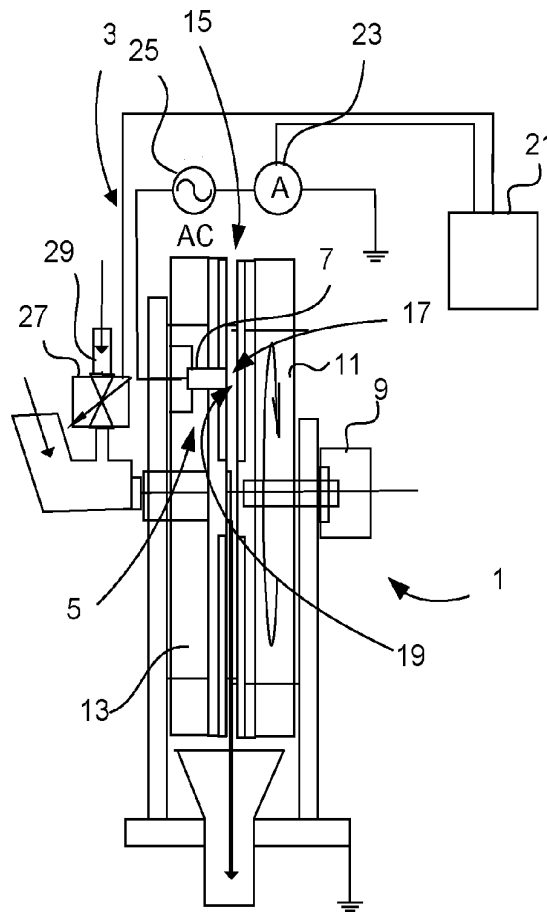

a-a