

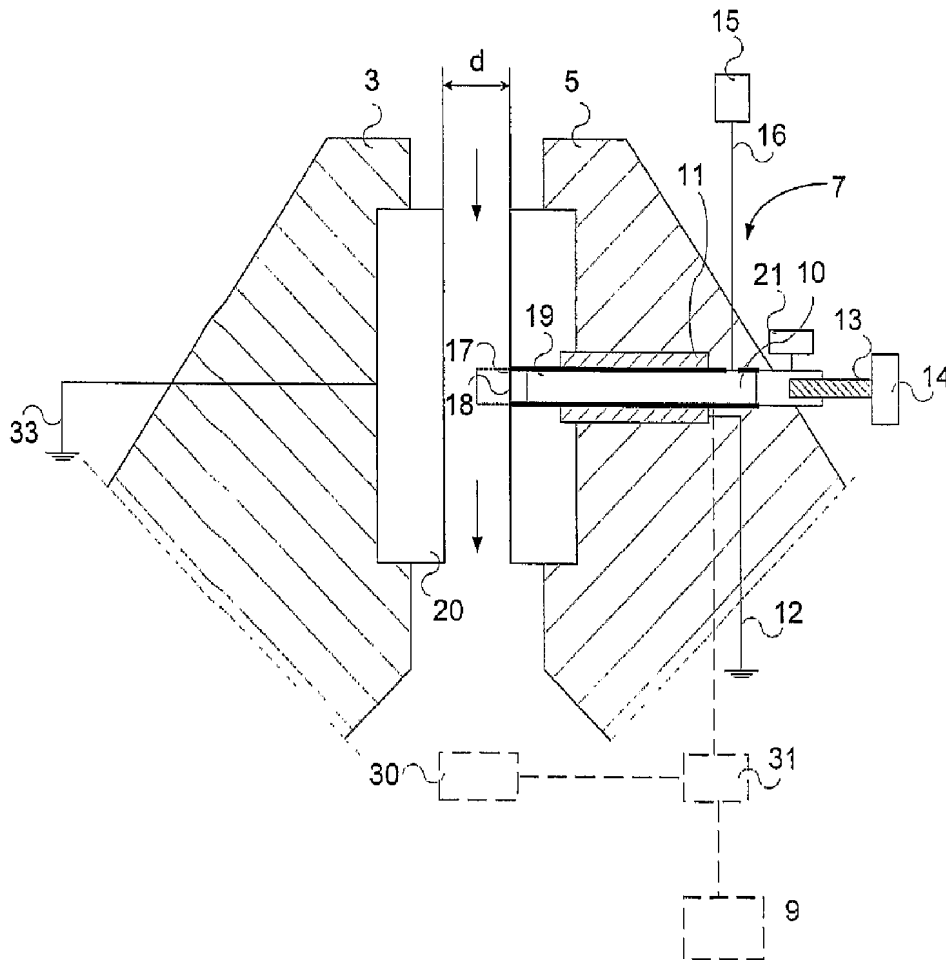

(86) Date de dépôt PCT/PCT Filing Date: 2005/02/25
 (87) Date publication PCT/PCT Publication Date: 2005/09/09
 (45) Date de délivrance/Issue Date: 2013/01/15
 (85) Entrée phase nationale/National Entry: 2006/08/24
 (86) N° demande PCT/PCT Application No.: SE 2005/000276
 (87) N° publication PCT/PCT Publication No.: 2005/083408
 (30) Priorités/Priorities: 2004/02/27 (SE0400491-7);
 2004/02/27 (US60/521,145)

(51) Cl.Int./Int.Cl. *G01N 27/02* (2006.01),
G01N 33/34 (2006.01)
 (72) Inventeur/Inventor:
 AKERBLOM, BENGT, SE
 (73) Propriétaire/Owner:
 DAPROX AB, SE
 (74) Agent: GOWLING LAFLEUR HENDERSON LLP

(54) Titre : PROCEDE ET DISPOSITIF DE MESURE DU DEGRE DE CONCENTRATION DE FIBRES
 (54) Title: PROCESS AND GAUGE FOR MEASURING FIBER CONCENTRATION



(57) Abrégé/Abstract:

The present invention relates to a method for measuring the degree of fibre concentration in a pulp in a machine (1), in particular a refiner for the manufacture of paper pulp, which machine (1) comprises a stator (5) and an opposing rotor (3), which form a

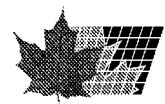

(57) **Abrégé(suite)/Abstract(continued):**

grinding gap (6) for the pulp. The stator (5) is provided with at least one sensor device (7), designed to interact with a rotor surface and comprising an impedance meter body (10) with a sensor surface (18) which impedance meter body (10) is mounted in the stator (5) in such a way that it can move axially. The method is characterized in that measurements of the impedance between the rotor surface and the sensor surface (18) are carried out during an axial movement of the impedance meter body (10) and in that the measured impedance differences are utilized together with the size of the movement to determine the dielectric constant of the pulp, from which the degree of fibre concentration in the pulp is derived. The invention also relates to a sensor device (7) arranged to carry out the method according to the above.