

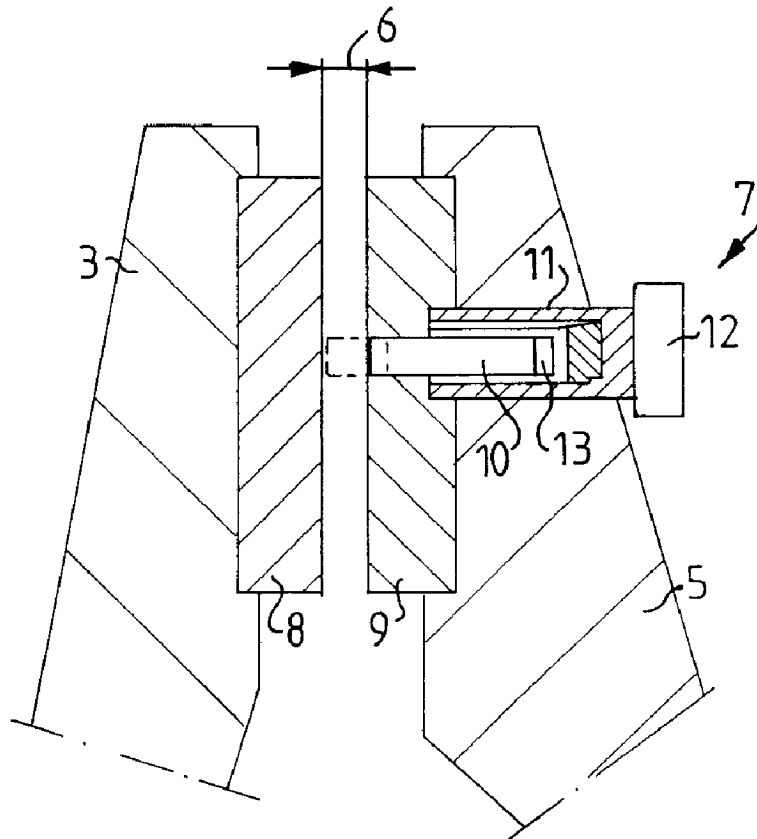

(86) Date de dépôt PCT/PCT Filing Date: 2001/03/20  
 (87) Date publication PCT/PCT Publication Date: 2001/09/27  
 (45) Date de délivrance/Issue Date: 2009/06/02  
 (85) Entrée phase nationale/National Entry: 2001/11/09  
 (86) N° demande PCT/PCT Application No.: SE 2001/000572  
 (87) N° publication PCT/PCT Publication No.: 2001/071276  
 (30) Priorité/Priority: 2000/03/23 (SE0001031-4)

(51) Cl.Int./Int.Cl. *G01B 7/14* (2006.01),  
*B02C 7/14* (2006.01), *D21D 1/00* (2006.01)  
 (72) Inventeur/Inventor:  
AKERBLOM, BENGT, SE  
 (73) Propriétaire/Owner:  
DAPROX AB, SE  
 (74) Agent: FETHERSTONHAUGH & CO.

(54) Titre : PROCÉDE ET DISPOSITIF DE MESURE DE DISTANCE  
 (54) Title: METHOD AND ARRANGEMENT FOR DISTANCE MEASUREMENT



(57) Abrégé/Abstract:

In a machine which is provided with a stator and an opposite rotor, a sensor of magnetic type, arranged in the stator, for determining the distance between the stator and the rotor can be calibrated by the sensor first being moved relative to the stator

(57) **Abrégé(suite)/Abstract(continued):**

into contact with the rotor for zeroing. The sensor is then reversed a predetermined distance, after which the sensor signal can be used for determining the distance between the stator and the rotor. In an arrangement suitable for the purpose, the stator has at least one sensor of magnetic type, which is intended to interact with an opposite surface on the rotor. The sensor is mounted displaceably in the axial direction of the rotor and can be brought into contact with the rotor.