

dametric 

AGS-SB170E

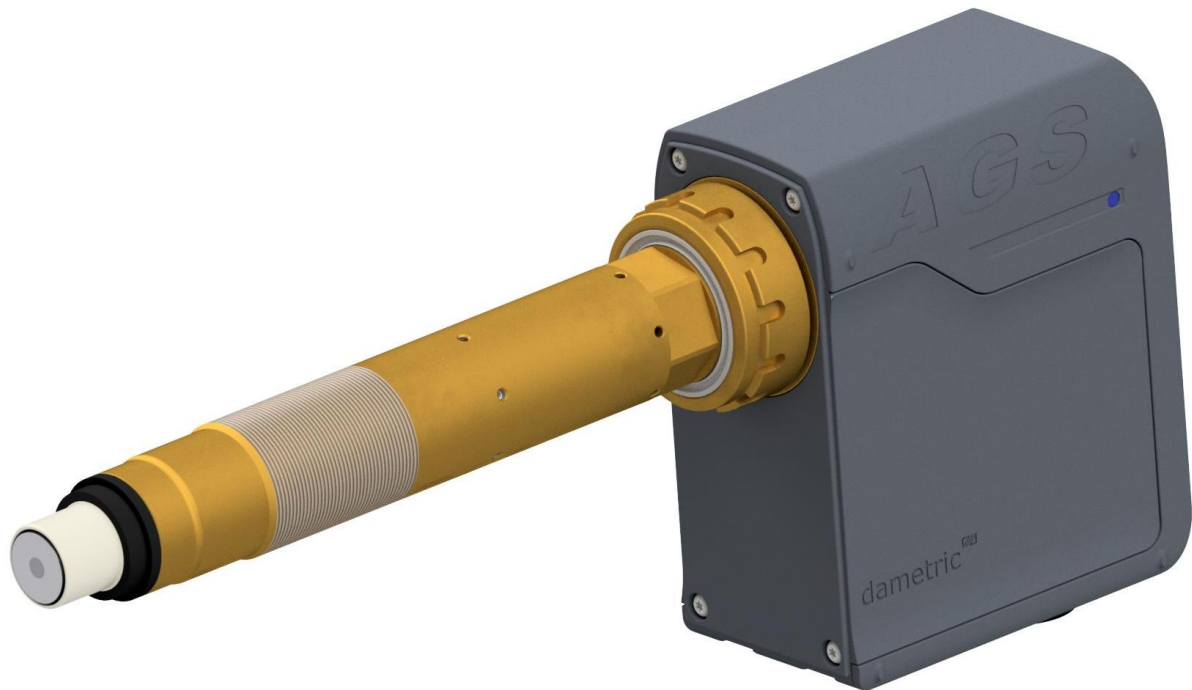

DESCRIPTION

ADJUSTABLE GAP SENSOR

**FOR ANDRITZ REFINERS
RTS SB-170 AND TWIN-66**

CONTENT

1	GENERAL	2
2	SPECIFICATIONS	3
3	SPARE PART LIST	3
4	SENSOR TIP MOUNTING	3
5	ELECTRICAL CONNECTIONS	3
6	COOLING AIR CONNECTION	3
7	WEAR LIMIT INDICATOR	3
8	MOUNTING	4
9	OUTLINE DRAWING	5
10	CONTACTS	5

1 GENERAL

The AGS (Adjustable Gap Sensor) is a distance measurement device designed to measure the disc gap in a pulp refiner. The measuring tip can be moved axially, which enables a complete automatic calibration during full production in the refiner.

AGS-SB170E will fit the Andritz SB-170 and the TWIN-66 refiners and is based on three main parts; a house, a holder and a sensor tip.

The house includes a mechanical adjustment device, an electrical stepping motor, an axial position sensor and a sensor for the touch point vibration.

The holder is a mechanical adaptor between the house and measuring tip to the mechanical dimensions of the TDC-hole in the refiner stator plate. The AGS sensor has the same mechanical dimensions in the tip end as the corresponding TDC-sensor so they are interchangeable.

The tip is a wear part and will wear as the segment plates are worn down. The tip is replaced periodically by the mill service personnel.

2 SPECIFICATIONS

Dimensions:	See outline drawing
Weight:	7.0 kg
House material:	Painted aluminium / Stainless steel
Holder material:	Stainless steel / Bronze
Sensor tip material:	Stainless steel
House temperature range:	0 – 65 °C
Tip temperature range:	0 – 225 °C
Wear range:	3 mm (see item WEAR LIMIT INDICATOR)
Connector:	19 pole MIL-C-5015 with aluminium case
Tip adjustment range:	± 2.50 mm.
Metso article no.:	VAL0323508

3 SPARE PART LIST

House:	AGD-HM3	Metso VAL0196738	
	or	AGS-HM-H4	Metso VAL0320980
Holder:	AGS-SP-SB170-HE	Metso VAL0323510	
Sensor tip:	AGS-XP-E250	Metso VAL0296313	
The installation also needs a sleeve for the refiner housing.			
Stator sleeve	AGS-SP-SB170-FE	Metso VAL0323509	

The sleeve is not included in the AGS sensor assembly and must be bought separately.

4 SENSOR TIP MOUNTING

Check the description of the sensor tip, AGS-XP-E250 on how it is changed.

Adjust the AGS holder part until the tip surface is flush with the segment plate surface.

5 ELECTRICAL CONNECTIONS

The AGS sensor is electrically connected to a connection box, KB-AGS1R, mounted on the refiner stand.

6 COOLING AIR CONNECTION

It is essential that the AGS sensor is cooled due to the warm steel plates around the AGS sensor.

Use instrument air which is clean, dry and oil free instrument air.

See our article AGS-SP-CS1 (Metso VAL0322341).

7 WEAR LIMIT INDICATOR

It is important that the sensor is not worn beyond the indicator marked in drawing below. Note that this is after the estimated plate life. A sensor worn beyond this point may result in a plate crash and furthermore affect the refiner security.



8 MOUNTING

- Remove the segment plate (A).
- Lubricate the O-ring (B), replace if necessary. Note, the sleeve (C) is an adapter to the refiner stator and is normally not replaced.
- Remove the AGS-tip.
- Separate the holder (D) from the house (G) by loosening the nut (F).
- Mount the holder in to the flange (C).
- Mount the AGS-house (G) to the holder, tighten the nut (F).
- Mount the measurement tip (E) according to the tip replacement manual.
- Back away the AGS-sensor by turning the holder (D).
- Bolt on the segment plate (A) make sure the segment doesn't rest against the holder (D).
- Screw the holder (D) until it reaches the segment plate, tighten.

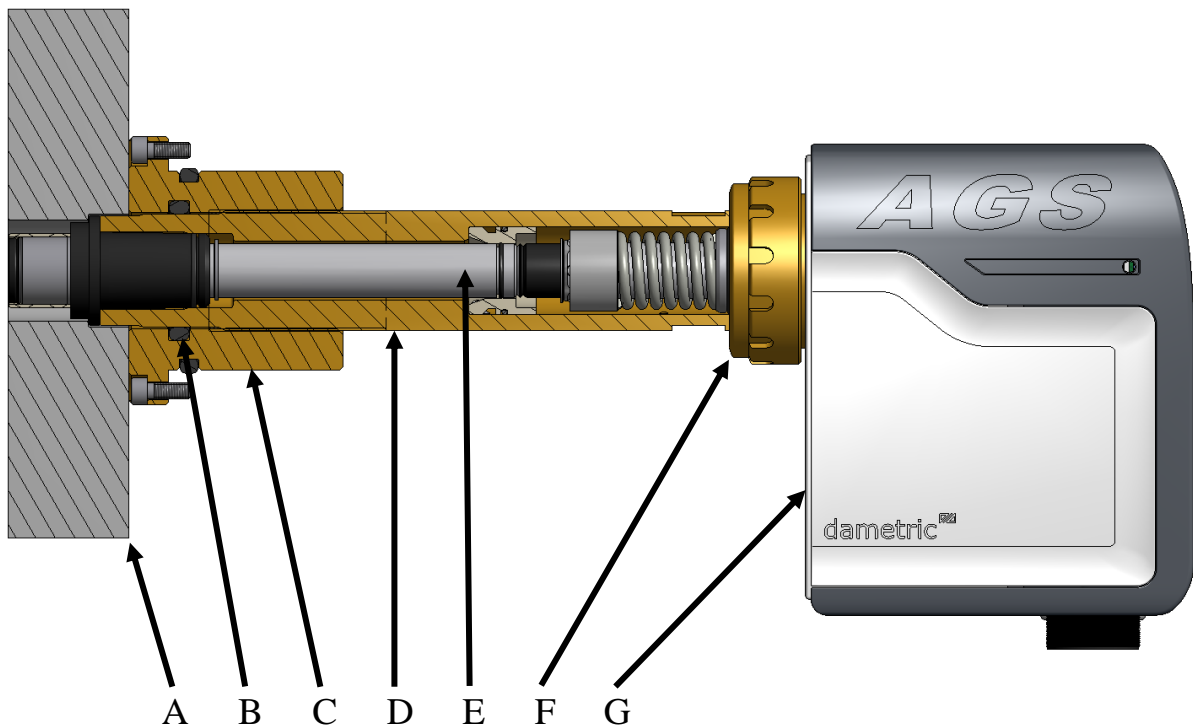

9 OUTLINE DRAWING

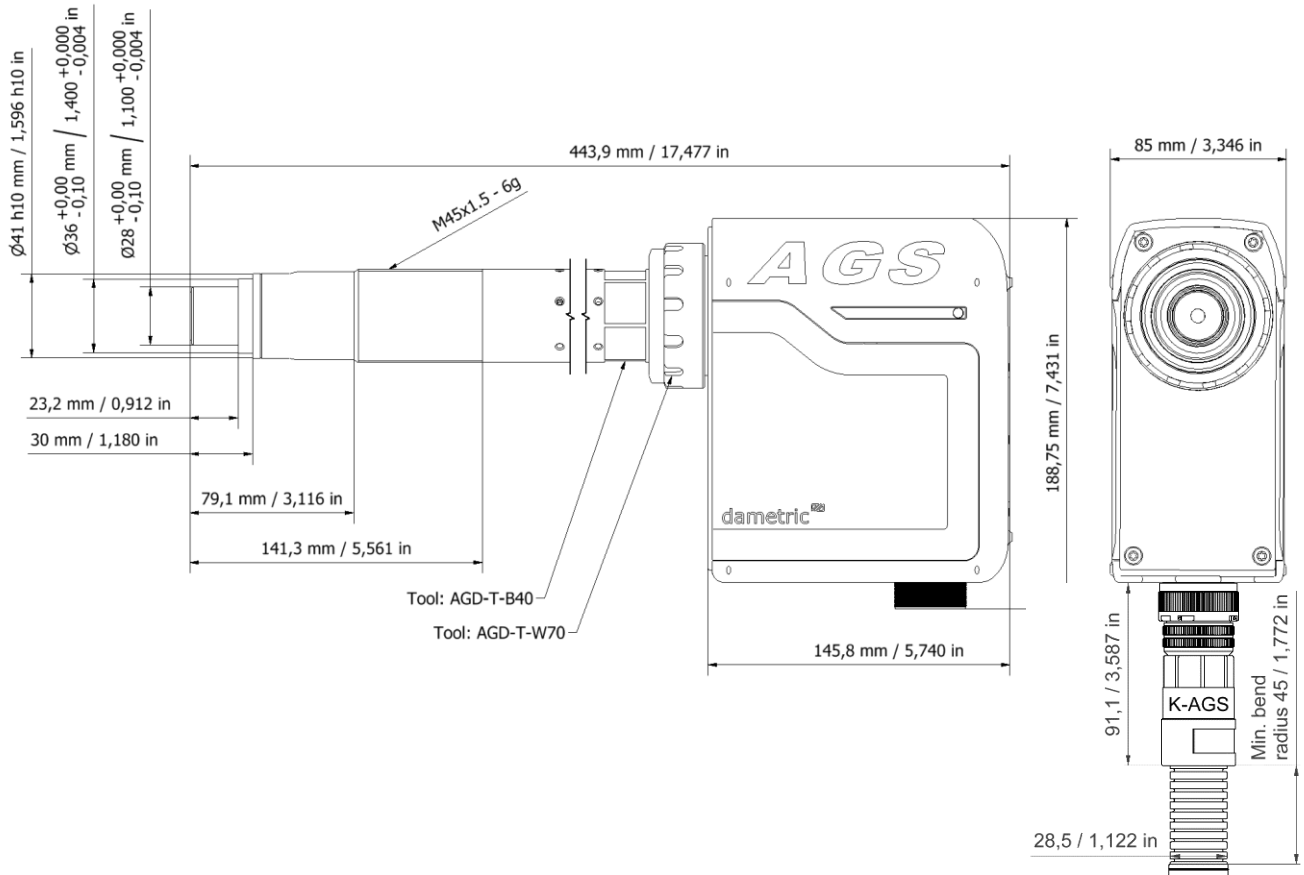

10 CONTACTS

Sales, development, production and service:

Dametric AB

Jägerhorns Väg 19, 141 75 Kungens Kurva, Sweden

Phone: +46-8 556 477 00

Telefax: +46-8 556 477 29

e-mail: ags@dametric.se

www.dametric.se

dametric 